

MG - 350

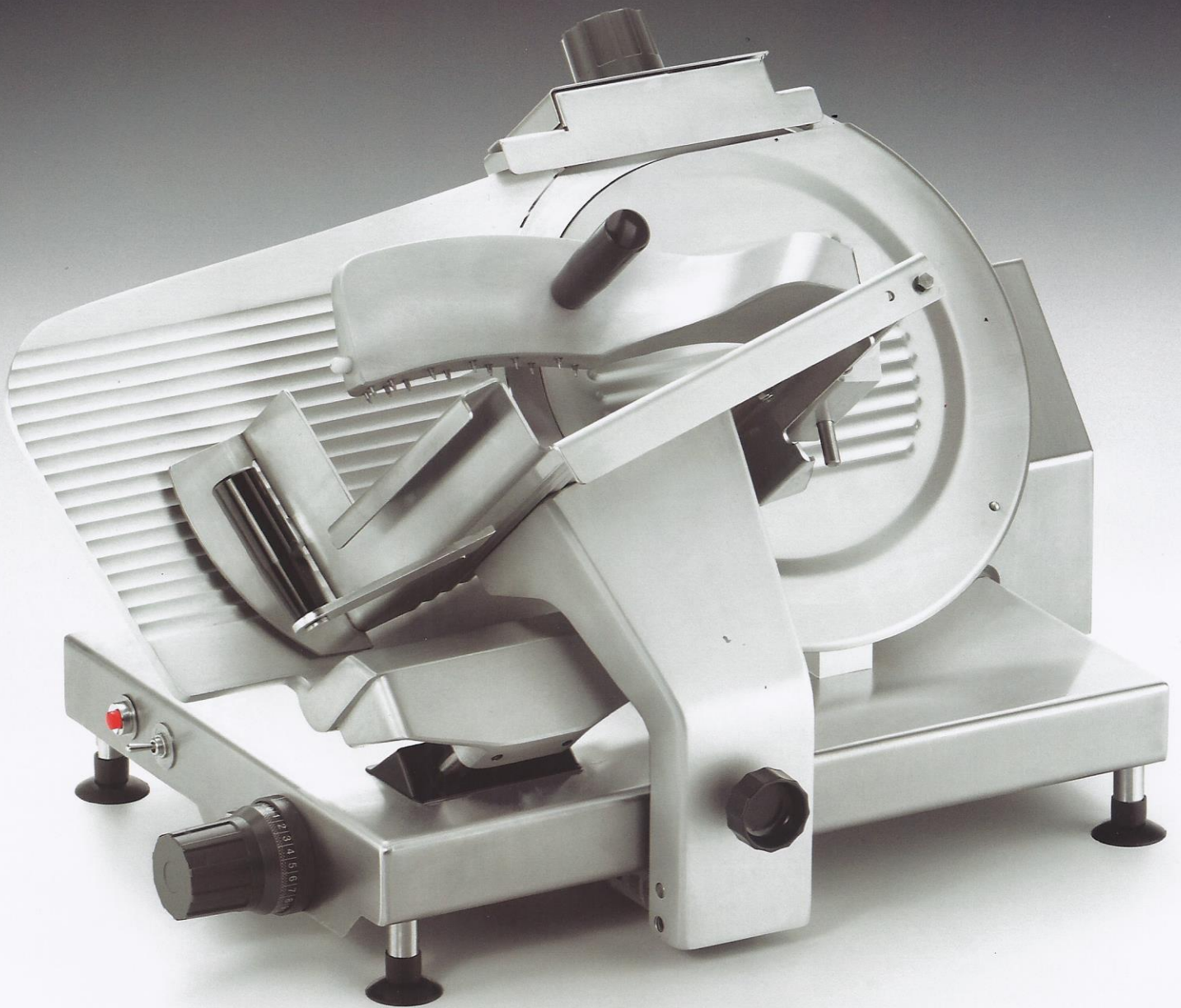

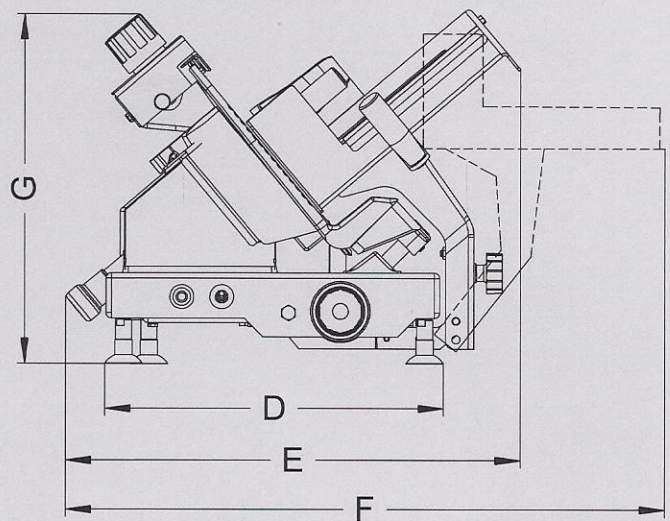
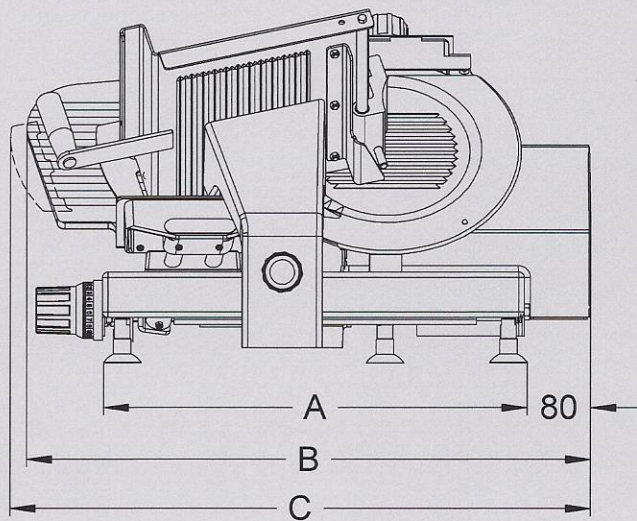

MOD.	A mm.	B mm.	C mm.	D mm.	E mm.	F mm.	G mm.	Cuchilla / Blade Ø mm.	Kg.	HP.	Capacidad de corte / Cutting capacity	
											Máx. Ø mm.	Máx. mm.
MG-350	580	760	775	440	590	755	455	350	68	0,4	250	305x205

- Rebanadora integrada de acero inoxidable 18/8 (Cromo/Níquel).
- Cuchilla 65 HRc (dureza), baño de cromo duro de 14 µ (micras).
- Cuchilla alemana de primera calidad (acero alto grado); resistente, garantizada para una capacidad de corte extraordinaria.
- Transmisión de engrane (sin fin corona).
- Afilador integrado sistema automático de fácil funcionamiento y limpieza.
- Motor monofásico de 0,40 H.P. de 127V., con ventilación periférica, manteniendo temperatura a bajo nivel.
- Carro portador de avance desmontable.
- Espesor de corte: 0-25 mm.

- Slicer constructed of 18/8 stainless steel (Chrome/Nickel).
- Blade, hardened 65 HRc, and hard chrome plated 14µ (micras).
- Best quality German blade (high steel grade); resistant, guaranteed for an extraordinary performance in cutting capacity.
- Crown drive transmission.
- Automatic blade sharpener attached, easy functioning and cleaning.
- Single Phase motor of 0,40 H.P. 127V., with cooling fan, maintaining a low operating temperature.
- Product carriage, detachable.
- Cutting thickness: 0-25 mm.

MEXCUT se reserva el derecho de modificación sin previo aviso.

MEXCUT reserves the right to make any modification without prior notice

Distribuidor / Distributor

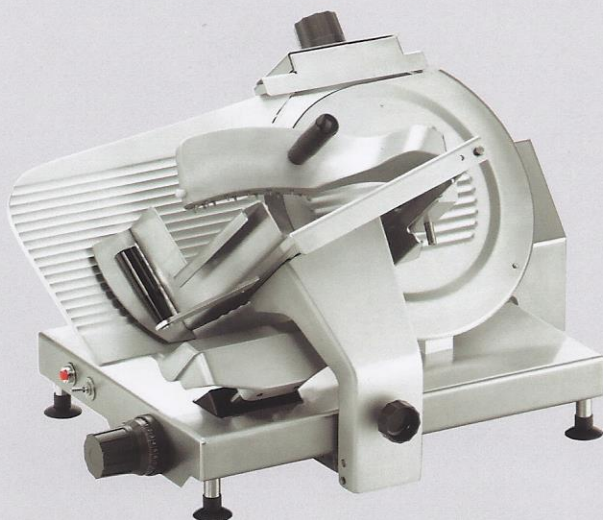

MEXCUT CORPORACION S.A. DE C.V.

Rancho Camichines, No. 25
COLONIA NUEVA ORIENTAL COAPA

14300 MEXICO D.F.

TEL.: (55) 56-79-89-89

FAX: (55) 56-79-65-40